

PODOLOGY UNITS

Innovative solutions for your professional success



GALIT



Why do podologists choose GALIT units for their practice?

QUALITY AND DURABILITY

The principal material for making a podology unit is 1 mm thick metal sheets characterised by a high durability and a long service life. Furthermore, a unit uses high quality components supplied by European manufacturers (FARO, EKOM, BIEN AIR, etc.)

ERGONOMICS AND FUNCTIONALITY

A GALIT unit is mounted on a strong metal plate provided with wheels, which ensures its mobility. A medical furniture module containing drawers allows a physician to organise his workspace so as to achieve the best productivity.

CLIENTS AND PERSONNEL SAFETY

The material and the design of the unit allow it to be easily freed from bacteria, viruses, and other contaminants, which makes it possible to maintain a high level of hygiene in rooms.

You are invited to the world of innovations in podology with GALIT!



High quality lighting from Faro brand is for health of physicians, and protects their eyes from an excessive strain.

A MAIA lamp provides you with an evenly illuminated field having a size of 170 x 95 mm. Power of luminous flux is 3,000 to 35,000 LUX.

The lamp is mounted on a pantographic console having three rotation axes, which makes its use as easy as possible.



The tools are controlled, switched on and off using a pneumatic pedal.



Tools in the unit are selected so as to meet the needs of the present-day podologist:

- MCX LED micromotor from Bien Air, whose maximum speed is 40,000 r/min;
- Three-action syringe from DCI for drying the nail plate;
- Dust ejector equipped with a special head for quick cleaning of the work area.

The medical unit is mounted on an ergonomic swivel arm, and has optical sensors for selection of tools.



The medical furniture module containing drawers and trays allows the physician to organise materials and inventory, and always have everything necessary at hand during the conduct of treatment procedures.

Different number of compartments in a tray allows to use the drawer space effectively.

Aesthetics and functionality

GALIT offers several models of podology units. For practices which do not have any compressor and aspiration unit, or do not have an additional room for accommodation of this equipment, we offer a self-contained unit equipped with built-in oil-free EKOM DK50-102 compressor, GALIT aspiration unit, and quickly detachable filter. Furthermore, there are models requiring connection to the compressor or the unit, or the both.

Every podology unit also includes a medical furniture module containing drawers for ideal organisation of the work process.

The physician can select a configuration of drawers depending on his needs.

Small drawers (s):

They are ideally suited to store medical tools, drugs, and other small supplies.

Medium drawers (m):

They are an excellent choice for storage of, for example, sterilised tool sets.

Large drawers (l):

They provide an excellent solution for organisation of documents, patient cards, and devices necessary in your practice.

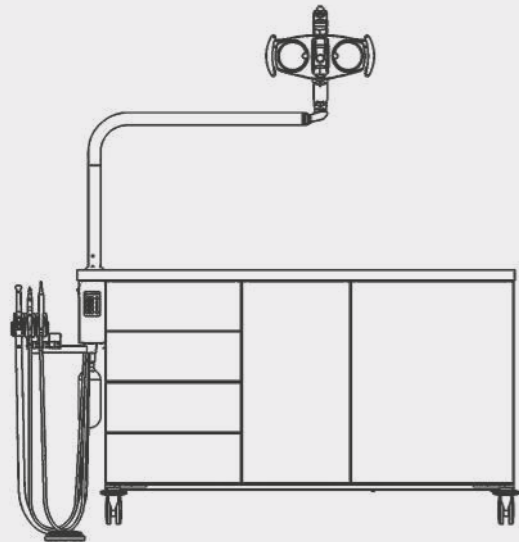

Podology unit equipped with an aspiration unit and a compressor

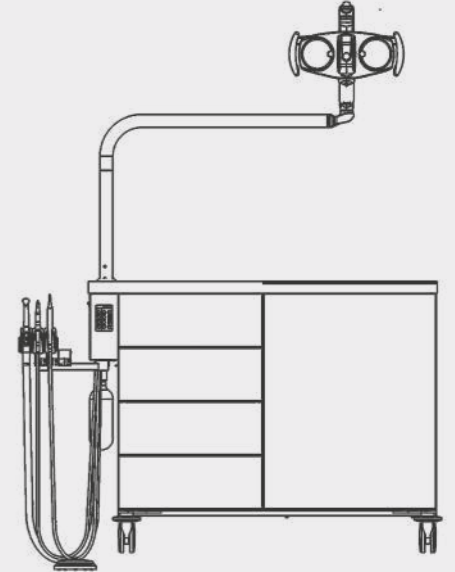

Podology unit equipped with a compressor and connected to an aspiration unit

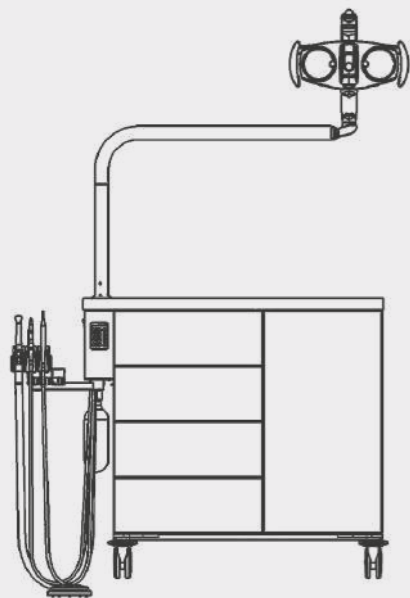

Podology unit equipped with an aspiration unit and connected to a compressor

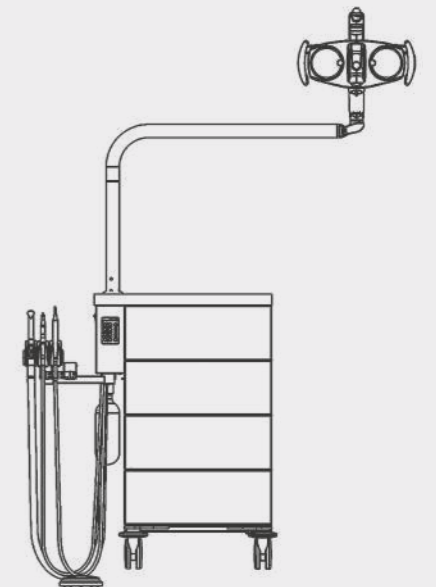
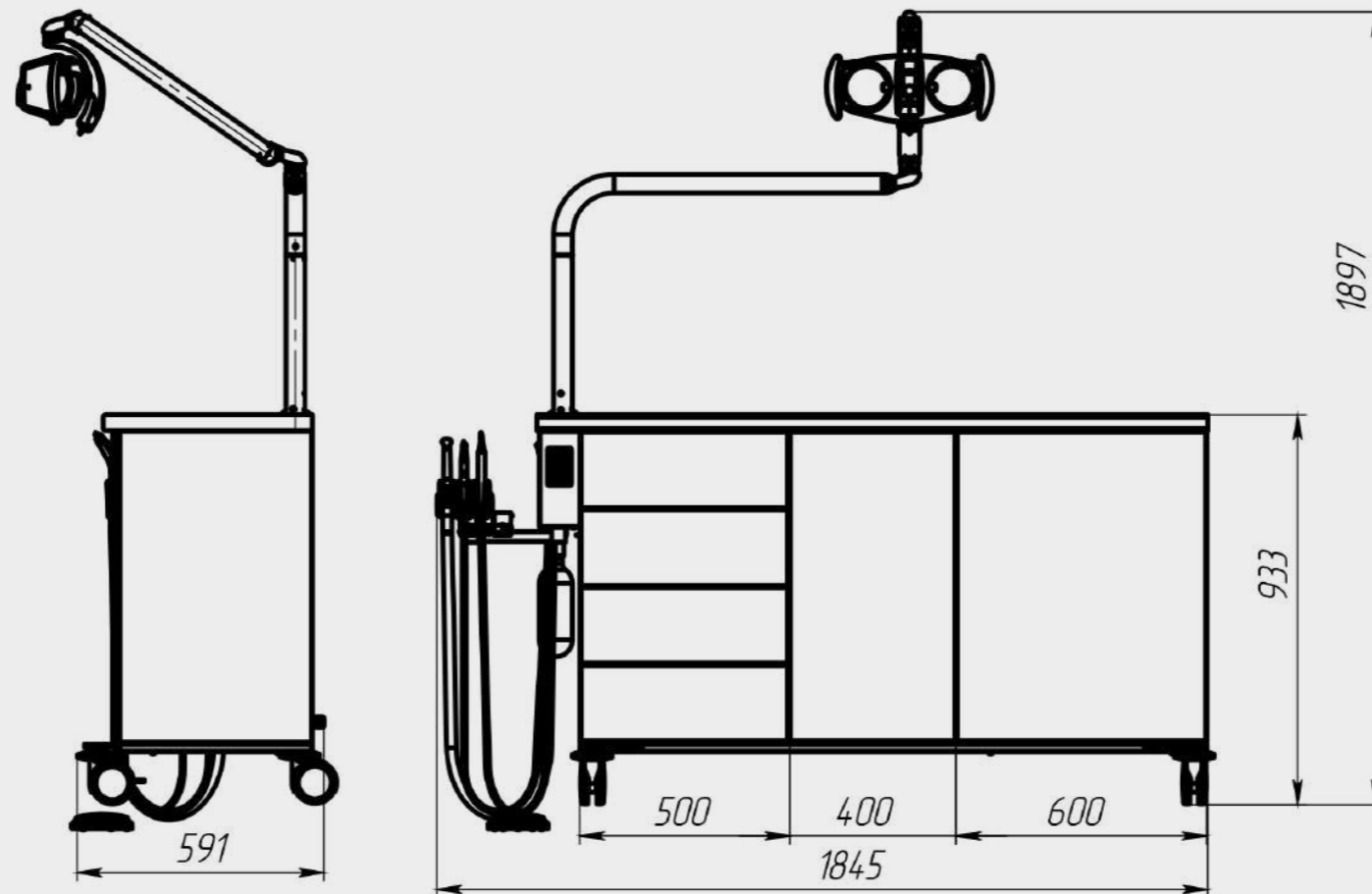

Podology unit connected to a compressor and an aspiration unit



Harmony between appeal to the eye and comfort

Benefit from the maximum comfort and effectiveness while using GALIT podology unit. Portable, compact Cart Autonome with ASP combines advanced technologies and an innovative design, which provides the highest standard of care for your patients.

Podology Cart has an integrated aspiration system ensuring perfect cleaning during every procedure. A soundproof cabinet provides calm and pleasant environment for physicians and patients. Antistatic wheels with fixing devices allow the unit to be easily moved, and provide comfort and flexibility in its use.

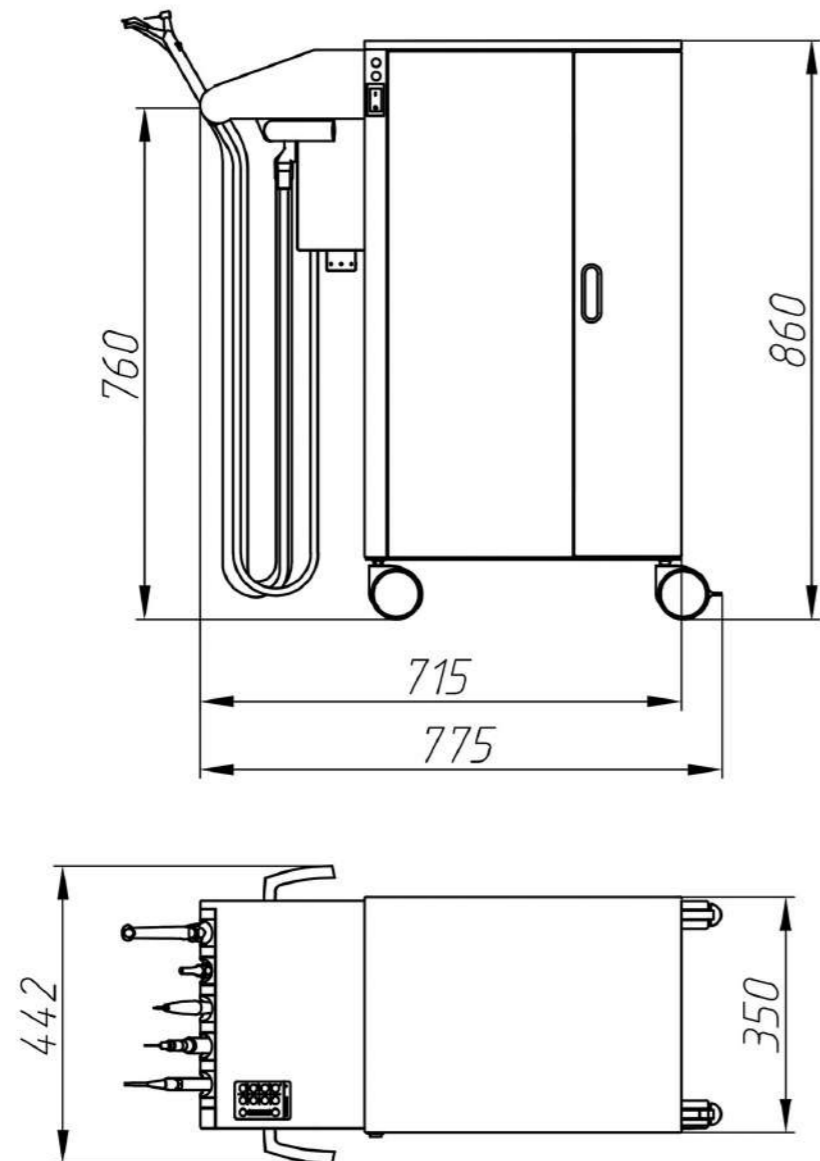

PRIMARY SPECIFICATIONS:

SOUNDPROOF WHEEL-MOUNTED CABINET WITH INTEGRATED:

- DK 50 compressor equipped with a stainless receiver providing stable and reliable pressure necessary for operation of all tools
- Aspiration unit equipped with a bactericidal filter ensuring cleanliness and safety during procedures.
- 5 L waste container ensuring easy and hygienic disposal of used materials and dust.

LIGHTING:

- Faro MAIA lamp having a power of up to 35 000 Lux, mounted on a pantographic console having three rotation axes, provides bright and even illumination of the work area, allowing the physician to precisely conduct all necessary procedures.

TOOLING WITH OPTICAL SENSORS:

- Dust ejector equipped with a head for effective dedusting to keep the work area clean.
- MCX LED micromotor having a speed of up to 40,000 r/min, which ensures operation with high precision.
- Three-action water-air DCI syringe for drying the nail plate.
- Turbine for procedures requiring to be conducted precisely and quickly.
- Pneumatic pedal for the control of tools.



Combine and create your style — Forget about limitations!

Medical furniture manufactured by GALIT will be an ideal addition to your practice. Two lines of furniture — Mercury and Sirius — open two worlds of design before you, and diversity of collections, types, and configurations of modules will allow you to create your unique design.

A range of medical furniture from GALIT numbers some hundreds of modules in different collections including leg-, plate-, chassis-mounted, mobile and suspended modules, also having different configurations including sink-, shelves- or drawers-type. Furthermore, GALIT has a wide range of top-mounted modules and dispensers allowing consumables to be conveniently placed and quickly accessed.

Combine different medical furniture modules and create your comfortable workspace which will ideally suit your needs.

GALIT medical furniture is reliable and durable, and is characterised by high resistance to wear and tear, because it is made of metal sheets. Metal as a material ensures resistance of structures and their high load-bearing capacity.

Designers from GALIT develop individual designs both for individual workstations and large practices, taking into account specific characteristics of a room and your needs.

From design to implementation, we endeavour to excel your expectations and provide an ideal experience of the use of our furniture.

GALIT

Manufacturer

PC Galit
6E, 15 Kvitnya Str., Baikivtsi, Ternopil region,
47711, UKRAINE

+380-800-502-998

office@galit.te.ua
service@galit.te.ua

European representative

Galdent CZ s.r.o.
K.Vapence 448, 41503 Teplice, Czech Republic

+420-775-471-378

export@galit.te.ua
galdentcz@gmail.com

C€ 2797

Version: 20241101

The technical specification or appearance of the equipment is subject to change without prior notice